

**Oracle Utilities Customer Care and Billing  
Release 2.3.1**

Utility Reference Model

4.2.1.1a Read Meter

July 2012

Oracle Utilities Customer Care and Billing Utility Reference Model 4.2.1.1a., Release 2.3.1

Copyright © 2012, Oracle and/or its affiliates. All rights reserved.

This document is provided for information purposes only and the contents hereof are subject to change without notice. This document is not warranted to be error-free, nor subject to any other warranties or conditions, whether expressed orally or implied in law, including implied warranties and conditions of merchantability or fitness for a particular purpose. We specifically disclaim any liability with respect to this document and no contractual obligations are formed either directly or indirectly by this document. This document may not be reproduced or transmitted in any form or by any means, electronic or mechanical, for any purpose, without our prior written permission.

Oracle and Java are registered trademarks of Oracle and/or its affiliates. Other names may be trademarks of their respective owners.

Intel and Intel Xeon are trademarks or registered trademarks of Intel Corporation. All SPARC trademarks are used under license and are trademarks or registered trademarks of SPARC International, Inc. AMD, Opteron, the AMD logo, and the AMD Opteron logo are trademarks or registered trademarks of Advanced Micro Devices. UNIX is a registered trademark licensed through X/Open Company, Ltd. 0611

---

---

# Contents

## Chapter 1

Overview..... 1-1

- Brief Description ..... 1-2
- Actors/Roles..... 1-2

## Chapter 2

Detailed Business Process Model Description ..... 2-1

- Business Process Diagrams..... 2-2
  - Read Meter Page 1 ..... 2-2
  - Read Meter Page 2 ..... 2-3
- Meter Read Description ..... 2-4
  - 1.0 Search for Meter ..... 2-4
  - 1.1 5.1.5.1 Manage Meter Site ..... 2-4
  - 1.2 Evaluate Meter Information ..... 2-5
  - 1.3 Evaluate Meter Read ..... 2-5
  - 1.4 Enter Meter Read ..... 2-5
  - 1.5 Enter Office Estimated Meter Read..... 2-5
  - 1.6 Request Add Field Activity ..... 2-5
  - 1.7 Add Field Activity ..... 2-6
  - 1.8 Enter Changes..... 2-6
  - 1.9 Update Read ..... 2-6
  - 2.0 Select Meters Required to be Read on Business Date ..... 2-7
  - 2.1 Retrieve Read Schedule, Route, Pending Meter Read Information..... 2-7
  - 2.2 Create Flat File for Download..... 2-8
  - 2.3 Receive Flat File..... 2-8
  - 2.4 Accept Downloaded Information in Reading Software/Handheld Devices ..... 2-8
  - 2.5 Obtain Read..... 2-8
  - 2.6 Enter Reason for Missed Read as Remark in Reading Software..... 2-8
  - 2.7 Create Flat File of Reads for Upload..... 2-9
  - 2.8 Send Flat File..... 2-9
- Meter Read Types..... 2-10
- Related Training..... 2-10



# Chapter 1

---

## Overview

This chapter provides a brief description of the Read Meter business process and associated process diagrams. This includes:

- **Brief Description**
  - **Actors/Roles**

## Brief Description

**Business Process:** 4.2.1.1a Read Meter

**Process Type:** Sub-Process

**Parent Process:** 4.2.1 Collect and Process Meter Read and Miscellaneous Charges

**Sibling Processes:** 4.2.2 Manage Bill; 5.3.2.1 Manage Field Activities and Field Orders; 4.2.1.2a Load Meter Reads; 4.2.1.3a Validate Meter Reads; 4.2.1.4 Manage Consumption Data Reporting

This process describes the cyclical meter reading process for meter service points as well as how to add and change ad hoc meter reads. Most organizations read their meters in assign routes with specific schedules. In addition, there are times when re-reads are required for verification, are obtained as part of another task, submitted by the Customer, or entered by a CSR or Authorized User.

## Actors/Roles

The Read Meter business process involves the following actors and roles.

- **CC&B:** The Customer Care and Billing application. Steps performed by this actor/role are performed automatically by the application, without the need for user initiation or intervention.
- **CSR CC&B:** CSR or Authorized User of the Customer Care and Billing application.

# Chapter 2

---

## Detailed Business Process Model Description

This chapter provides a detailed description of the Read Meter business process. This includes:

- **Business Process Diagrams**
  - **Read Meter Page 1**
  - **Read Meter Page 2**
- **Meter Read Description**
- **Meter Read Types**
- **Related Training**

# Business Process Diagrams

## Read Meter Page 1

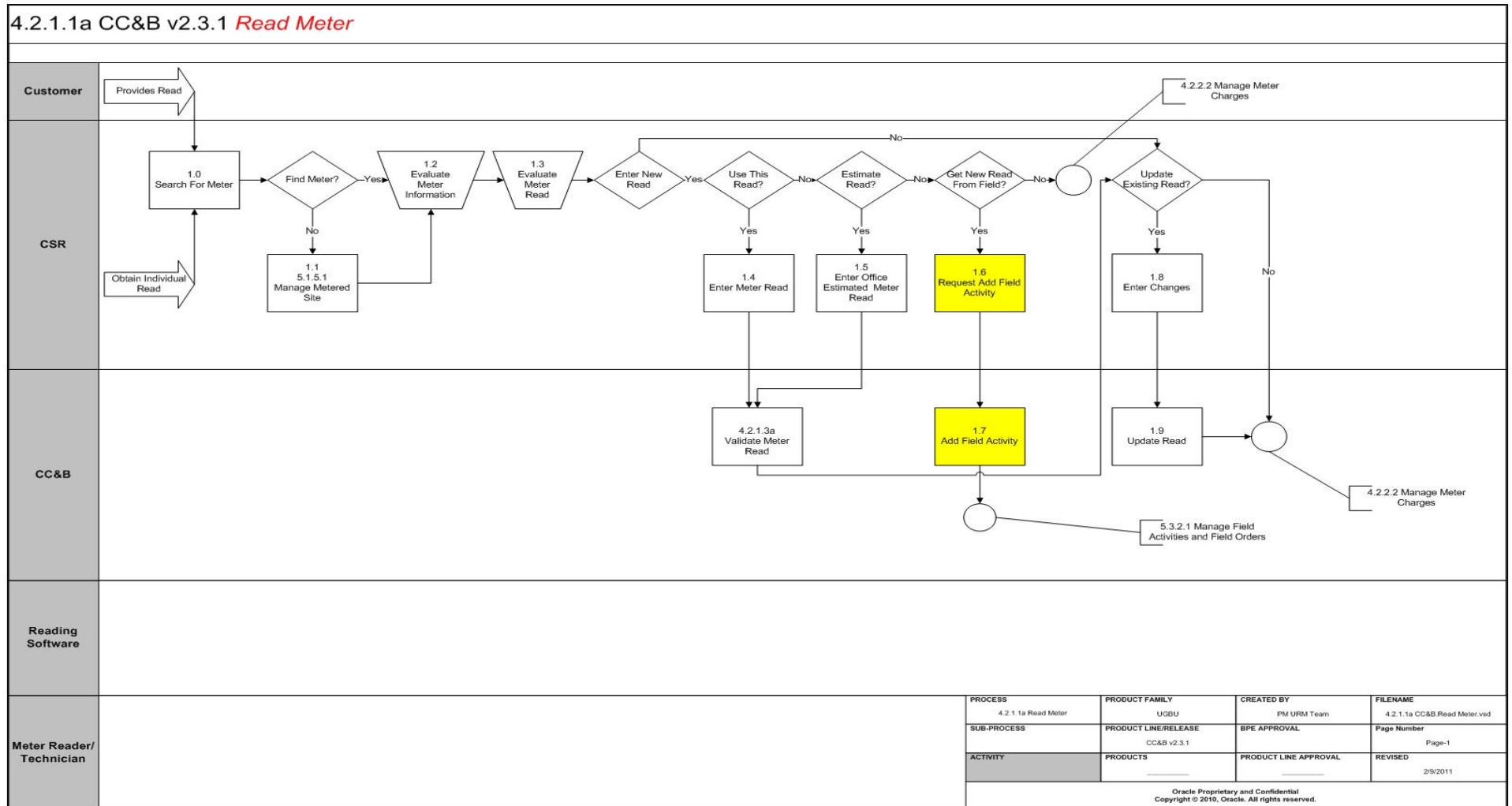



# Read Meter Page 2

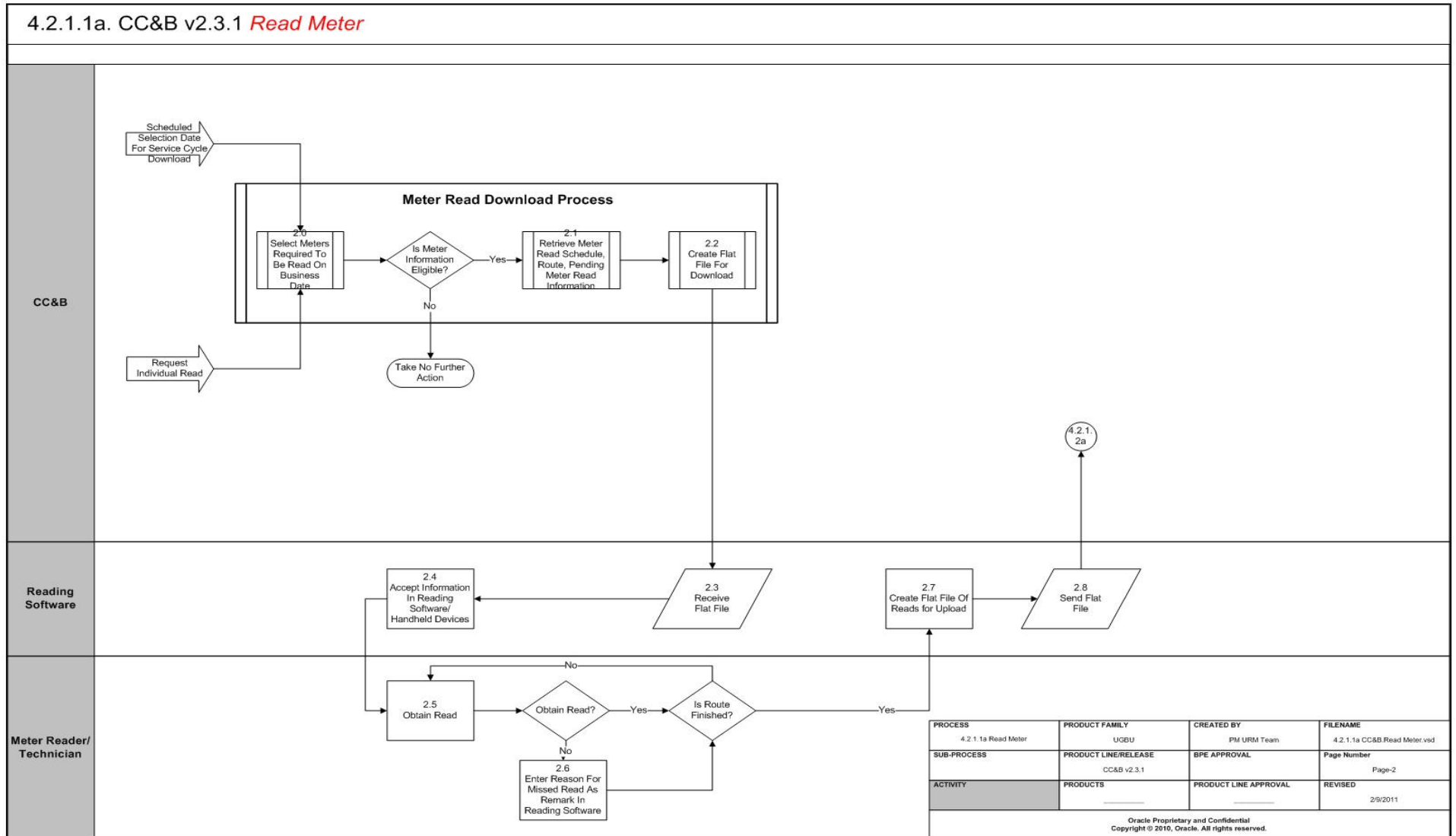

## Meter Read Description

This section includes detailed descriptions of the steps involved in the Read Meter business process, including:

- **1.0 Search for Meter**
- **1.1 5.1.5.1 Manage Meter Site**
- **1.2 Evaluate Meter Information**
- **1.3 Evaluate Meter Read**
- **1.4 Enter Meter Read**
- **1.5 Enter Office Estimated Meter Read**
- **1.6 Request Add Field Activity**
- **1.7 Add Field Activity**
- **1.8 Enter Changes**
- **1.9 Update Read**
- **2.0 Select Meters Required to be Read on Business Date**
- **2.1 Retrieve Read Schedule, Route, Pending Meter Read Information**
- **2.2 Create Flat File for Download**
- **2.3 Receive Flat File**
- **2.4 Accept Downloaded Information in Reading Software/Handheld Devices**
- **2.5 Obtain Read**
- **2.6 Enter Reason for Missed Read as Remark in Reading Software**
- **2.7 Create Flat File of Reads for Upload**
- **2.8 Send Flat File**

### 1.0 Search for Meter

See **Read Meter Page 1** on page 2-2 for the business process diagram associated with this activity.

**Actor/Role:** CSR

**Description:** The CSR or Authorized User searches for the Meter to enter a read. The read typically is provided by the Customer, exception processing, or a missed read during the meter read process. The Meter number or Badge Number as referenced in CC&B may be used to search for the Meter. Alternate search methods are used with the Meter/Item Search Notebook.

### 1.1 5.1.5.1 Manage Meter Site

See **Read Meter Page 1** on page 2-2 for the business process diagram associated with this activity.

**Actor/Role:** CSR

**Description:** If the Meter cannot be located in CC&B, the CSR or Authorized User, may add the meter to inventory in CC&B. Refer to 5.1.5.1. Manage Meter Site.

---

**Entities to Configure**

---

Meter Type

Meter Configuration Type

Meter Model and Manufacturer

---

## 1.2 Evaluate Meter Information

See **Read Meter Page 1** on page 2-2 for the business process diagram associated with this activity.

**Actor/Role:** CSR

**Description:** The CSR or Authorized User reviews and validates meter type information including what consumption the meter measures, number of dials, meter constant or meter multiplier, and how the meter is used to calculate consumption.

## 1.3 Evaluate Meter Read

See **Read Meter Page 1** on page 2-2 for the business process diagram associated with this activity.

**Actor/Role:** CSR

**Description:** The CSR or Authorized User compares the read to be entered against read history for this meter as well as consumption trends for the service point. The CSR or Authorized User checks to see if other reads are already entered for the same time period and makes comparisons.

## 1.4 Enter Meter Read

See **Read Meter Page 1** on page 2-2 for the business process diagram associated with this activity.

**Actor/Role:** CSR

**Description:** The CSR or Authorized User accepts the read and enters the meter read information.

## 1.5 Enter Office Estimated Meter Read

See **Read Meter Page 1** on page 2-2 for the business process diagram associated with this activity.

**Actor/Role:** CSR

**Description:** The CSR or Authorized User enters the office-estimated meter read information.

## 1.6 Request Add Field Activity

See **Read Meter Page 1** on page 2-2 for the business process diagram associated with this activity.

**Actor/Role:** CSR

**Description:** It is determined a new read is required from the field. The CSR or Authorized User enters required information to obtain a new read. Refer to 4.2.2 Manage Bill.

---

**Entities to Configure**

---

Field Activity Type  
Field Activity Profile  
Field Service Controls

---

## 1.7 Add Field Activity

See **Read Meter Page 1** on page 2-2 for the business process diagram associated with this activity.

**Actor/Role:** CC&B

**Description:** The field activity is added in CC&B. Refer to 5.3.2.1 Manage Field Activities and Field Orders.

## 1.8 Enter Changes

See **Read Meter Page 1** on page 2-2 for the business process diagram associated with this activity.

**Actor/Role:** CSR

**Description:** The CSR or Authorized user examines an existing read to determine if updates are required. Based on business rules, typically the only field the CSR or Authorized User modifies is the Use on Bill flag field. It is recommended to maintain an audit trail of all reads entered. The best practices approach is to remove the use on bill flag on a particular read if it is incorrect or will not be used for billing. The CSR or Authorized User can enter a new read as needed.

## 1.9 Update Read

See **Read Meter Page 1** on page 2-2 for the business process diagram associated with this activity.

**Actor/Role:** CC&B

**Description:** CC&B is updated with changes for the read. Refer to 4.2.2 Manage Bill.

---

**Entities to Configure**

---

Meter Read Type  
Meter Read Remark  
Characteristics related to Meter Read  
Meter Read source  
Meter Read Instructions (Related to Premise)  
Meter Read warnings (Related to Premise)

---

Business Objects	Available Algorithm(s)
CI_MeterReadAudit Meter Read Audit for Auditing Purpose only when Auditing is on.	CI_MREAD_BO - Determine Meter Read BO. This algorithm is defined on the MO and allows use of Business Object.  CI_MeterReadAudit Meter Read Audit for Auditing Purpose only when Auditing is on.

## 2.0 Select Meters Required to be Read on Business Date

See **Read Meter Page 2** on page 2-3 for the business process diagram associated with this activity.

**Actor/Role:** CC&B

**Description:** The scheduled selection date is reached. This is the date read information is available to Field Operations staff for reading. Requests for off cycle reads are received and available to Field Operations staff.

## 2.1 Retrieve Read Schedule, Route, Pending Meter Read Information

See **Read Meter Page 2** on page 2-3 for the business process diagram associated with this activity.

**Actor/Role:** CC&B

**Description:** This process looks for all meter read cycle schedules with a scheduled selection date on or before the given business date with routes not yet generated. For each record found this process creates a Meter Read schedule route record for every route in the cycle. This process reviews all the Meter Read schedule route records flagged for download and creates a record for every meter in a given route flagged as available for download. The system also selects the service points in the meter read cycle for download. Refer to 4.2.1.5 Maintain Meter Read Schedule.

### Entities to Configure

Service Schedule

Service Cycle

### Customizable Processes

**MSR - Create MR Schedule Routes.** This process looks for all meter read cycle schedules with routes not generated. Route Records are created for every route in cycle

**MDS - Create Download Staging.** This process creates download staging records for meters linked to every service point in route

## 2.2 Create Flat File for Download

See **Read Meter Page 2** on page 2-3 for the business process diagram associated with this activity.

**Actor/Role:** CC&B

**Description:** This process reads all records marked for download with a given Batch Control ID and run number, and creates the flat file for Field Operations' various meter read software applications.

---

### Customizable Processes

---

MDL - Create Download Flat File

---

## 2.3 Receive Flat File

See **Read Meter Page 2** on page 2-3 for the business process diagram associated with this activity.

**Actor/Role:** Reading Software

**Description:** The reading software in Field Operations receives the flat file.

## 2.4 Accept Downloaded Information in Reading Software/Handheld Devices

See **Read Meter Page 2** on page 2-3 for the business process diagram associated with this activity.

**Actor/Role:** Reading Software

**Description:** Meter Read Information is downloaded to reading software and/or handheld devices in preparation for reading in the field.

## 2.5 Obtain Read

See **Read Meter Page 2** on page 2-3 for the business process diagram associated with this activity.

**Actor/Role:** Meter Reader/Technician

**Description:** A technician is routed to the field to collect reads.

## 2.6 Enter Reason for Missed Read as Remark in Reading Software

See **Read Meter Page 2** on page 2-3 for the business process diagram associated with this activity.

**Actor/Role:** Meter Reader/Technician

**Description:** At times it may not be possible to obtain the read from the customer's meter. An obstruction, clouded glass, or animal may prevent the reader the reader from getting the read. An entry is made in the reading software to communicate the reason the read was not obtained. Comments from the Meter Reader can trigger a Field Activity, Customer Contact or Bill Message. Refer to 4.2.1.2a Load Meter Reads.

---

### Entities to Configure

---

Field Activity Type

Bill Message

Customer Contact Class and Contact Type

MR Remarks

---



---

### Available Algorithm(s)

---

MRRCRERESAM - this algorithm creates an Account Message to be placed on bill (Meter Read Remark Algorithm)

MRRCRECC - this algorithm creates a Customer Contact from Meter Read Remark

CI\_CREMRCSE - This algorithm creates a case from Meter Read Remark

MRR-SIO This algorithm creates M-SIO Meter - service investigation Field Activity

MRRCREMRFA - Create "Re-read meter" field activity

CI\_MREAD\_BO - Determine Meter Read BO

---



---

### Customizable Processes

---

MRRRA - Background process read remark activation

---

## 2.7 Create Flat File of Reads for Upload

See **Read Meter Page 2** on page 2-3 for the business process diagram associated with this activity.

**Actor/Role:** Reading Software

**Description:** The reading software prepares a flat file containing reads and meter information for Upload to CC&B.

## 2.8 Send Flat File

See **Read Meter Page 2** on page 2-3 for the business process diagram associated with this activity.

**Actor/Role:** Reading Software

**Description:** Reading Software in Field Operations sends a flat file to CC&B for Upload to CC&B.

## Meter Read Types

Read Type	Description
Billing Force	Meter reads with this value are entered by a billing administrator who wants to force billing to bill a customer for a given amount of consumption.
Verified	A meter reader using a handheld device records meter reads with this value. The handheld device deems a read as "verified" if the meter reader typed the same dial reading in twice. Some organizations have their handhelds programmed to require the double entry of dial readings when the entered value is outside normative values (i.e., the resultant consumption fails high / low checks).
Regular	A meter reader using a handheld device records meter reads with this value. See the description for "verified" above for the difference between a "regular" and a "verified" reading.
Customer Read	A customer provides meter reads with this value.
System Prorate	Meter reads with this value are created by the system automatically when prorating normal cycle-based reads for use with an off-cycle start service or stop service.
Office Estimate	Meter reads with this value are informed guesses of consumption. These would be used when there was no real reading (i.e., a regular or verified reading), and the system was not allowed to estimate consumption (for whatever reason). This value is rarely used.
Service Provider Estimate	Meter reads with this value are estimates of consumption made by a 3rd party service provider, such as an MDMA, the distribution company, or an energy supply company.
System Estimate	The billing process creates meter reads with this value when a reading cannot be found and the service agreement allows estimation.
No Read	Meter reads with this value are entered to indicate that a read was purposefully not performed (for whatever reason - mad dog, nasty rose bush, deep snow, etc.). A read with this value is not a read at all; it's just an audit trail.

## Related Training

The following User Productivity Kit (UPK) modules provide training related to this business process:

- Oracle Utilities UPK for Customer Care and Billing, Administrative Setup
- Oracle Utilities UPK for Customer Care and Billing, Rating and Billing for Interval Data